

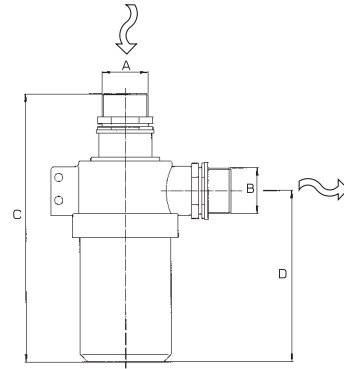

M125



Standard completi di attacchi G1 1/2M.

Versioni: 125.503.1 - lunghezza 280 mm - cartuccia 46mesh
 125.503.2 - lunghezza 280 mm - cartuccia 25mesh
 125.503.4 - lunghezza 360 mm - cartuccia 46mesh
 125.503.5 - lunghezza 360 mm - cartuccia 25mesh

Peso: 620 g

Materiali: materiali plastici ad alta resistenza - acciaio inox

Impiego: in aspirazione su gruppi da diserbo ed atomizzatori. Completati di valvola di ritegno per pulizia cartuccia con filtro in linea.

Standard with 1 1/2" BSPM. connections

Models: 125.503.1 - 280 mm lenght - 46mesh screen
 125.503.2 - 280 mm lenght - 25mesh screen
 125.503.4 - 360 mm lenght - 46mesh screen
 125.503.5 - 360 mm lenght - 25mesh screen

Weight: 620 g / 22 oz

Materials: high resistance plastic materials - stainless steel

Use: on air blast and boom sprayers suction line. Built in valve for screen cleaning with M125 in line.

COME SI ORDINA / HOW TO ORDER

CODICE code	VERSIONE model	MESH CARTUCCIA screen mesh	PORTATA l/min flowrate USGal/min	A	B	C mm	D mm	
125.503.1	280 mm	46	150 - 40	G1 1/2M.	G1 1/2M.	280	185	5
125.503.2	280 mm	25	180 - 48	G1 1/2M.	G1 1/2M.	280	185	
125.503.4	360 mm	46	200 - 53	G1 1/2M.	G1 1/2M.	360	265	
125.503.5	360 mm	25	230 - 61	G1 1/2M.	G1 1/2M.	360	265	

CARTUCCE / SCREENS



COME SI ORDINA / HOW TO ORDER

CODICE code	VERSIONE model	MESH CARTUCCIA screen mesh	MATERIALI materials	
125.203.14	280 mm	46	PP/ACCIAIO INOX - PP/s. steel	5
125.203.15	280 mm	25	PP/ACCIAIO INOX - PP/s. steel	
125.203.25	360 mm	46	PP/ACCIAIO INOX - PP/s. steel	
125.203.26	360 mm	25	PP/ACCIAIO INOX - PP/s. steel	

GIUNTI PG / PG HOSE SHANKS

Materiali: PP
 Attacco: G1 1/2F.

Materiali: PP
 Connection: 1 1/2" BSPF.



COME SI ORDINA / HOW TO ORDER

CODICE code	Ø	VERSIONE model	
124.1502.24	30	90°	10
124.1502.25	35	90°	
124.1502.26	40	90°	
124.1502.27	30	DIRITTO-straight	
124.1502.28	35	DIRITTO-straight	
124.1502.29	40	DIRITTO-straight	